

# Modeling and Simulation of Supervisory Control and Data Acquisition (SCADA) system for Water-quality models

Hussein Tbena Kadhim, Ali H.Kadhym, Mohammad E .Abdullah

**Abstract**— This paper focuses particularly to design a Ladder logic diagram a for monitoring qualities within a drinking water system. This system includes sensors & Electrical Interfaces to PLC (Programmable Logic Controller) for transmitting/receiving control and status data. The chosen water quality parameters , one is the physical quality parameter of a water is Turbidity which provides an inexpensive estimate of total suspended solids (NTU) concentration and one is chemical pH value which stands for "potential of Hydrogen". Exposure to extreme pH values results in irritation to the eyes, skin and mucous membrane and free chlorine CL concentration should be monitored to ensure that it is sufficient for its purpose .A program and a laboratory prototype were built to simulate the real water system. The research was compared with water and Environmental research center of MOST.

**Index Terms**— Ladder Logic Diagram, PLC, water quality sensors, SCADA

## 1 INTRODUCTION

In response to the problems in Iraqis major monitoring system of water quality such as weak sampling capability of water quality, untimely data processing and lack of early warning mechanism of water quality change, based on SCADA technology, the design scheme of an automatic water quality monitoring system is proposed

Based on a review of available online water quality monitoring sensor technologies, an early determination was made that it was not technically feasible to accurately identify and quantify the many different types of contaminants that could potentially be introduced into the drinking water supply/distribution system. Furthermore, because online sensor technologies need to be economically suitable for mass deployment within a distribution system, this paper focused its research on identifying sensor technologies that could be used to detect anomalous changes in water quality due to contamination.

SCADA systems are widely used in most industrial processes .It provides information on real time basis, which helps to identify the problem as they occur and take corrective action when needed. Proper monitoring of process can maintain operations at an optimal level by identifying and correcting problems before they turn into significant system failure

The safety of drinking water supplied to the consumers by water treatment plant operators is dependent upon many factors: quality of raw water (surface water and/or ground water), application of appropriate treatment technology/disinfection (as needed), and monitoring of treated/finished water within the water distribution system network [1]. The automation system extends work at [2] and previous Energy and Water Quality Management System (EWQMS) projects sponsored by AwwaRF [3, 4, 5]. The best way to improve the water distribution system is by using industrial PLC and PC system, which includes all network components like flow sensor, GSM modules, pH sensor etc [6]

Prior to introduction of contaminants, water-quality sensors located within the selected test apparatus (TU

8355 , pH- P7615 ,CL7635) were, typically monitored for an hour to establish normal (baseline) conditions. After contaminant injection, data from the three sensors were monitored and recorded.

Turbidity refers to how clear the water is. The greater the amount of total suspended solids (NTU) in the water, the murkier it appears and the higher the measured turbidity [7]. Very high levels of turbidity for a short period of time may not be significant and may even be less of a problem than a lower level that persists longer. The figure below shows how aquatic organisms are generally affected as shown in Fig.1.

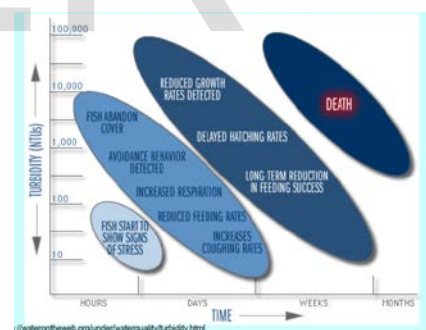

Fig.1 Duration Turbidity is important factor

Pollution tends to reduce water clarity. Watershed development and poor land use practices cause increases in erosion, organic matter, and nutrients, all of which cause increases in suspended particulates and algae growth [8].

The parameter applicability of pH is an Indicator of hydrogen ion activity (acidity or alkalinity) of water. Most chemical and biochemical processes are pH dependent. Carbon dioxide/bicarbonate/ carbonate and ammonia/ammonium equilibrium are pH dependent. pH of drinking water is well established and controlled. A change of more than 0.5 pH unit indicates a problem [1]. Fig.2 has shown the pH values for different liquids.

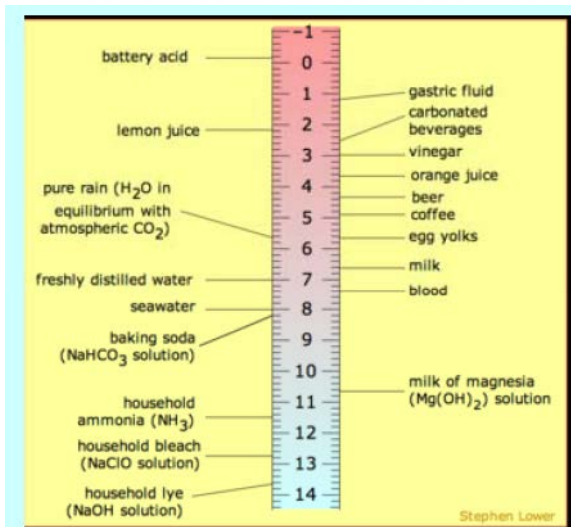

Fig.2 pH values for different liquids

Chlorine (CL) Today chlorine is the most common disinfectant used by water treatment plants. Chlorine is an excellent oxidant and serves well as a disinfectant; the disinfection capabilities of chlorine are highly dependent on the temperature, pH, and organic content of the water. The main purpose of disinfecting public water supplies is to prevent the spread of waterborne diseases. Free chlorine concentration should be monitored to ensure that it is sufficient for its purpose. It is important for utilities to continuously monitor free chlorine in order to identify dosing those times when chlorine demand suddenly increases, and take steps to ensure a detectable free chlorine in the system.

## 2 PROJECT DESIGN

The project design consider the main efficient water qualities (one Physical and tow Chemical) .Thus the, Turbidity TU 8355 sensor [10] pH- P7615sensor [9], Chlorine 300349 (CL) sensor [11] are used in the control system respectively. The required water parameters pre-determined according to the table1. These values according to the Iraqi criteria and standards for drinking water (IQS: 417/2009) (ICS: 13.060.20) according to[12].

TABLE 1

Suggested parameters to be monitored

Parameter	Units	Min	Max	Normal
pH	pH	6.5	8.5	6.5-8.5
TU	NTU	0	5	0-5
CL	Mg/L	0.3	2	0.3-2

The block diagram of the control system shown in the Fig.3.Each block in the figure represents a system component. The solid lines with arrows indicate the flow of signals between the components. The controller (PLC) inputs are the reference inputs (also called a set points of pH, CL and TU) and the plant output signal (measured by the sensor, real values of these parameters), which is

used as feedback. A block in a diagram represent something as simple as a constant value that multiplies the block input, with no known mathematical representation.

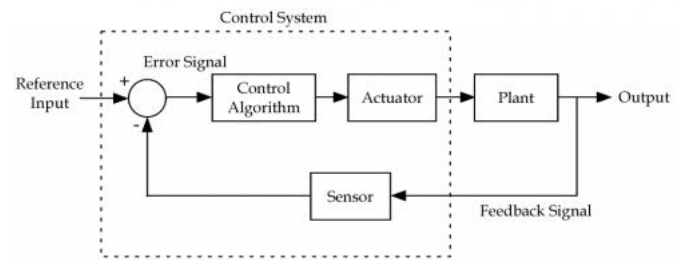

Fig.3 A block diagram of an elementary feedback control system [13]

The controller output is the actuator signal that drives the plant (motor fan, lights, and buzzer) as shown in the Fig.4



Fig.4 The output control signals

## 3 WATER PARAMETERS LADDER LOGIC DIAGRAM

The flow chart of the LADDER logic diagram starts by reading the analog parameters from the designed laboratory water basin (Fig.5) in real time, then makes scaling for these parameters values and transforms from analog to digital by (A/D) unit in the PLC, these values can be calculate from these equations:

$$y=(x-3.7)/1140 \dots\dots\dots (1)$$

$$y=(x-7)/800 \dots\dots\dots (2)$$

$$y=4604-3.263x+0.000579x^2 \dots\dots\dots (3)$$

Where: "equation (1)," for pH,"(2) for CL and "(3)" for Tu.

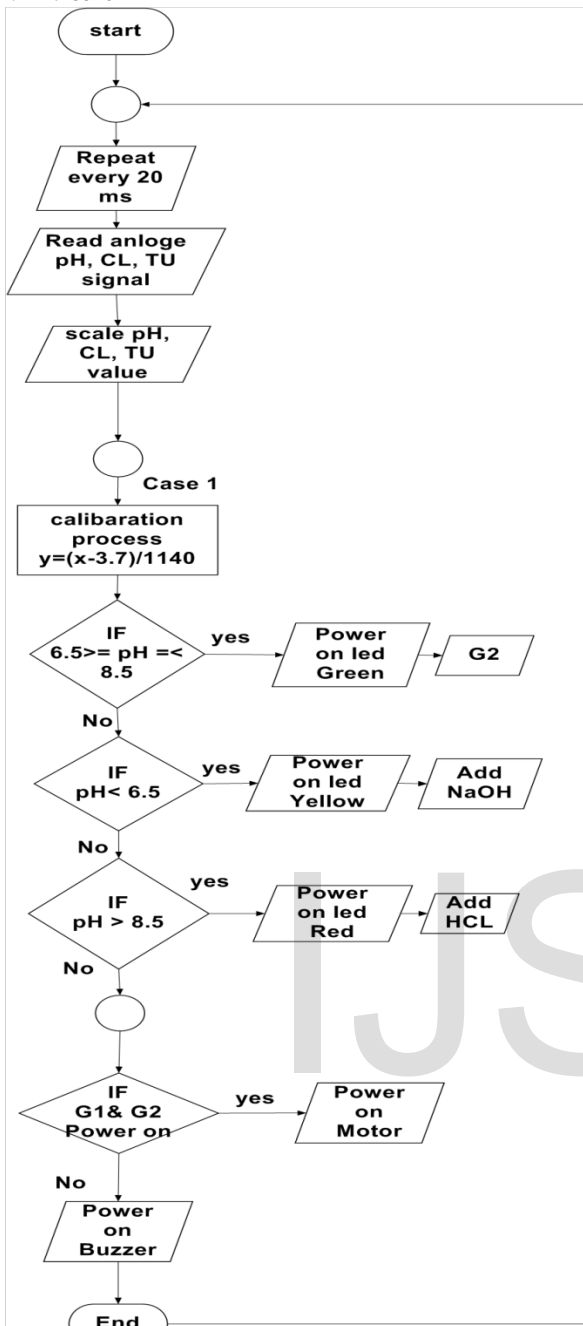

Fig.5Flow chart of the LADDER logic diagram

To calculate the parameters changes with time, and store these values in (I/O) unit which can be reading during the operation process for water treatment, the flow chart divided in to three cases:

Case one: reading the pH value, the readings between 6.5-8.5(7428.5-9714.3) analog, the green led ignited that mean normal case and acceptable for human use as shown in Fig.2.

If the pH value less than 6.5 that mean the water is acid the yellow led is ignited that dangerous for human use and buzzer warring turn on. Then add Sodium hydroxide (NAOH).

Finally if the pH value greater than 8.5 which mean the water is alkalinity or basic that dangerous for human use so the red led ignited and buzzer warring turn on. Then add Hydrochloric acid (HCL).

The sensors will repeat the readings every 20 ms.as shown in Fig.6

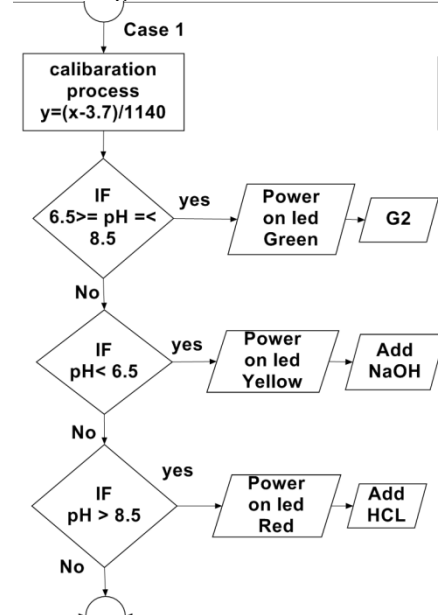

Fig.6Case one from flow chart of the LADDER logic diagram

The same method for turbidity and free chlorine.

The PLC will perform the control according to the logic or LADDER program fed into it by the user using CICON software linked with PLC. The PLC is also programmed to send message if the problem occurs when the system is in progress.

The calibration process of these signals must be calibrated to display it as script of their real time values on the HMI unit.

The system working Automatically every interval of the time which already determined by timer function( 20 ms) as pre-programmed .The screen shoot of the LADDER logic program showing in Fig.7. The LADDER logic diagram contains an arrangement of series instructions of a rung programmed for optimum scan time. The series instructions are programmed from the most likely to be false (far left) to the least likely to be false (far right). Once the processor sees a false input instruction in series, the processor stops checking the rung at the false condition and sets the output false. An arrangement of parallel instructions of a rung programmed for optimum scan time. The parallel path that is most often true is placed on the top of the rung.

The rungs (1,10 and 19) represent the input from sensors, the rungs (6,15 and 24) represent the scaling of the data by converting from limit PLC to limit of sensors, the rungs (7,8,9,16,17, 18,25,26 and 27) represent the condition of pH, CL and TU sequentially, (y10.y11,y12,y13,y14 and y15) represent output of the system., rung 28 represent motor condition.

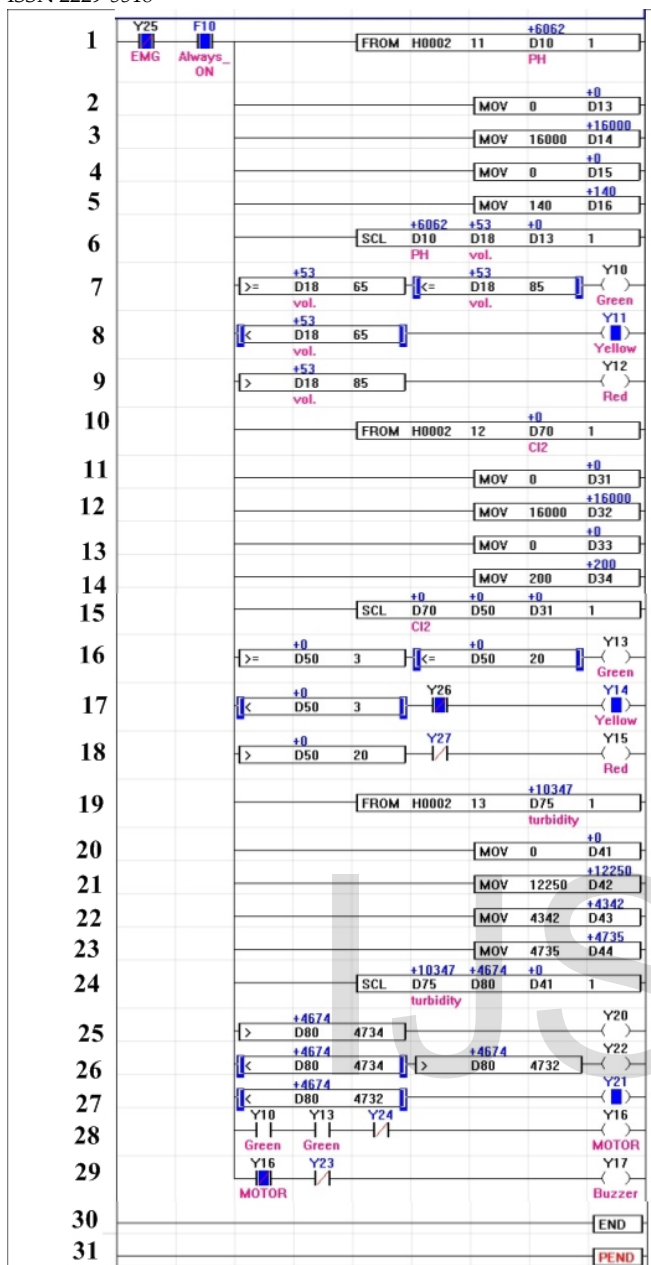

Fig.7 LADDER logic diagram

The Laboratory model shown in Fig.7, the small vessel with three sensors and PLC hardware. The three sensors working as an input parameters which have an output analog signals (0-20mA). These signals processed as digital signals in PLC (CIMON type). The PLC accepts the input from the pH, Turbidity and Chlorine sensor and compares it with the standard values already fed into the PLC.



Fig.8 Hardware of the control system

The samples of water were collected from Tiger river and regional filtered water, and tested directly with ambient Temp 25C, and sun light. The sample of real time readings can be shown in Fig.9.

	A	B	C	D	E
	Time	PH	CL	TU	
1					
2	September 08 2015 11:17:28	8.25	0.00	1.43	
3	September 08 2015 11:17:58	8.25	0.00	1.92	
4	September 08 2015 11:18:28	8.25	0.00	1.92	
5	September 08 2015 11:18:58	8.25	0.00	86.16	
6	September 08 2015 11:19:28	8.25	0.00	3.78	
7	September 08 2015 11:19:58	8.25	0.00	8.53	
8	September 08 2015 11:20:28	8.25	0.00	8.92	
9	September 08 2015 11:20:58	8.25	0.00	3.00	
10	September 08 2015 11:21:28	8.25	0.00	3.00	
11	September 08 2015 11:21:58	8.25	0.00	11.33	
12	September 08 2015 11:22:28	8.25	0.00	11.33	
13	September 08 2015 11:22:58	8.25	0.00	11.33	

Fig.9. Sample of the readings

These readings were obtained for row water samples of Tiger River and the test was at 25C.

#### 4 THE RESULTS AND DISCUSSION

For the purpose of understanding the effect of using PLC controller on the data collection of drinking water parameters by measuring these parameters in real time and recording its.

It has been drawing these parameters for fresh water for a period of times and reading these values by controller and converting to the PLC for the purpose of show it on the HMI screen.

The SCADA data dump from the case study contains the sensor values which are recorded every 30 second as shown in the Fig.10.

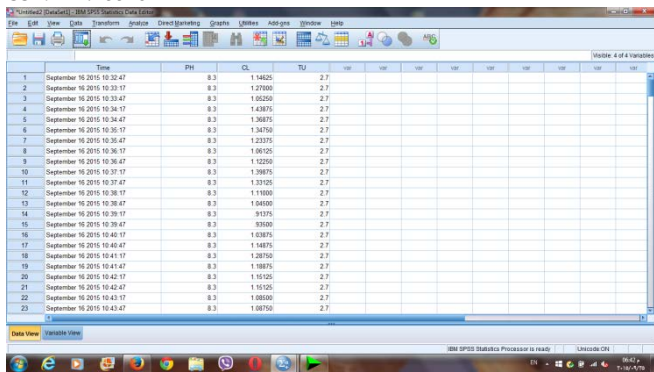

Fig.10 TU, pH, & CL, Sensor values by SPSS

Data cleansing is applied to the SCADA data dump with the purpose of eliminating any measurement points that have the potential to cause inaccurate validation results by using SPSS software. Applying data cleansing to the SCADA data dump before utilizing them in the validation, is essential to avoid inaccurate validation results which lead to incorrect analysis. Statistical analysis is applied to the SCADA data dump to reveal further information that can be useful in the validation process. Statistical methods that will be applied are Descriptive Statistic and Correlation Analysis. Initially, the data distribution of each sensor can be obtained from the Histogram, as shown in Fig.11.

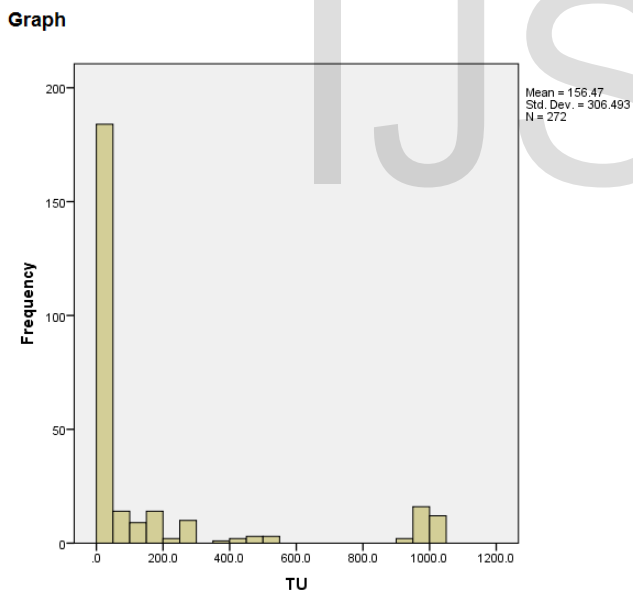

Fig.11. SPSS results for Turbidity

The high column in the Fig.11 indicates the most acceptable readings and it is commutable with the table.1.In the Descriptive Statistic, initially the data from each sensor is plotted on the histogram to provide preliminary information about the data distribution. Then, several parameters are assessed such as:(Mean, Median, Mode, Variance, Standard Deviation, Maximum, Minimum, Range, Interquartile Range, Skewness and Kurtosis),tables.2,3,4 described these parameters.

TABLE 2  
Descriptive Statistic for Turbidity

► Explore

Case Processing Summary

	Cases					
	Valid		Missing		Total	
	N	Percent	N	Percent	N	Percent
TU	272	100.0%	0	0.0%	272	100.0%

Descriptives

		Statistic	Std. Error
TU	Mean	156.474	18.5838
	95% Confidence Interval for Mean	Lower Bound 119.886 Upper Bound 193.061	
	5% Trimmed Mean	117.875	
	Median	10.689	
	Variance	93937.724	
	Std. Deviation	306.4926	
	Minimum	2.7	
	Maximum	1011.2	
	Range	1008.5	
	Interquartile Range	107.5	
	Skewness	2.119	.148
	Kurtosis	2.942	.294

TU

Turbidity describes water clarity, the greater the amount of suspended impurities in water. Based on the Control Philosophy, the maximum Turbidity for the system is (0-50) NTU. Therefore, if the value is 50 NTU, the turbidity is not acceptable and it is suspected that there is something wrong in the system by alarm red light flashing in the output control box.

Further information that can be obtained from the Descriptive Statistic is as follows:

Some value of Turbidity is out of the Turbidity threshold; that is, more than 5 NTU. The result from this test supports the conclusion that the data distribution for Turbidity is not a normal distribution.

The pH measurement is used to determine the relative acidic or basic level of water by measuring the concentration of hydrogen ions. The pH scale ranges from 0 to 14; pH 7 means neutral, below 7 is more acidic and above 7 is more basic. pH is one of the crucial parameter for potable water; therefore, it is very important to monitor the pH level.

**Graph**

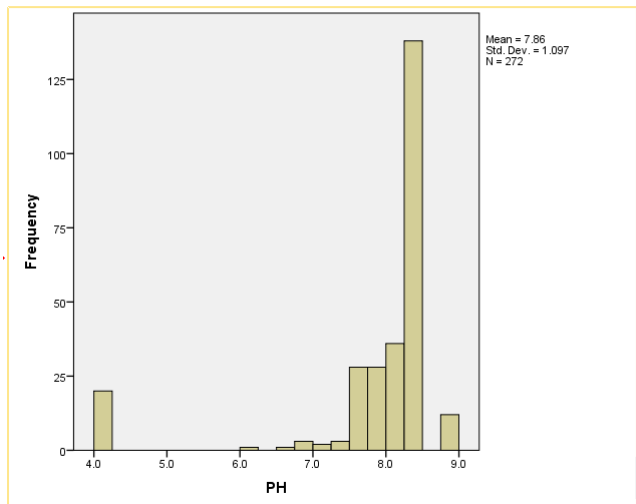

Fig.12.SPSS results for pH

Based on the Control Philosophy, the pH must be maintained between 6.5 and 8.5. If pH is outside that range, the mechanism to revise the pH level is triggered to take the pH level back in the range. Therefore, if the value from the pH sensor is out of the range, it means that there is something wrong with the mechanism to revise the pH level and the red light and buzzer and stopped motor fan which is represented the flow motor.

**TABLE 3**  
 Descriptive Statistic for pH

➔ **Explore**

[DataSet1]

**Case Processing Summary**

	Cases					
	Valid		Missing		Total	
	N	Percent	N	Percent	N	Percent
PH	272	100.0%	0	0.0%	272	100.0%

**Descriptives**

		Statistic	Std. Error	
PH	Mean	7.857	.0665	
	95% Confidence Interval for Mean	Lower Bound	7.726	
		Upper Bound	7.988	
	5% Trimmed Mean	8.007		
	Median	8.295		
	Variance	1.203		
	Std. Deviation	1.0969		
	Minimum	4.1		
	Maximum	8.9		
	Range	4.8		
	Interquartile Range	.5		
	Skewness	-2.741	.148	
	Kurtosis	6.528	.294	

**PH**

Further information that can be obtained from the Descriptive Statistic as:

1. Some value of pH is out of the pH threshold. It is expected that the Filtering Algorithm is able to filter these values in the validation process.

2. By comparing the Mean and Median, the data distribution for pH is not normal distribution.

3. pHZscore from: Skewness = 18.5, and Kurtosis = 22.2.

$2.5 \times \text{Standard Deviation} = 2.74225$ .

Therefore, the Zscore is much larger than 2.5 times standard deviation. The result from this test gives more support to the conclusion that the data distribution for pH is not in normal distribution.

According to the control philosophy, the minimum level of the free chlorine residual is 0.3 mg/L. If the value is below this level, the system probably does not work properly, as shown in the Fig.13.

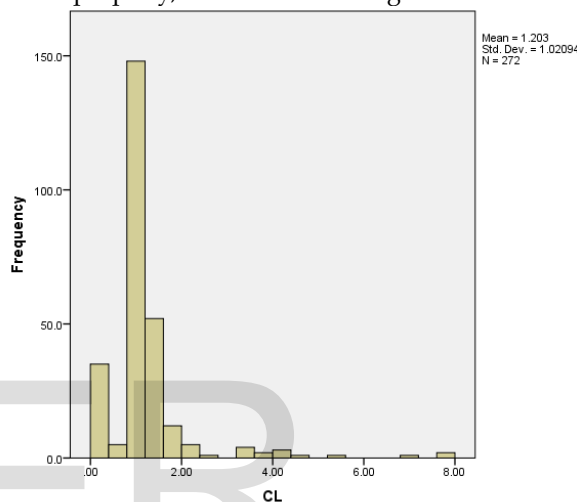

Fig.13SPSS results for CL

Further information that can be obtained from the Descriptive Statistic is:

1. Some value of Chlorine is out of the Chlorine threshold; that is, less than 0.3 mg/L. It is expected that the Filtering Algorithm is able to filter these values in the validation process.

2. By comparing the Mean and Median, the data distribution for Chlorine is not a normal distribution.

3. Chlorine Zscore from: Skewness = 23.6, and Kurtosis = 60.17.

$2.5 \times \text{Standard Deviation} = 2.5525$ .

Therefore, the Zscore is much larger than 2.5 times standard deviation. Results from this test give more support to the conclusion that the data distribution for Chlorine is not in normal distribution.

**TABLE 4**  
 Descriptive Statistic for CL

► **Explore**

**Case Processing Summary**

	Cases					
	Valid		Missing		Total	
	N	Percent	N	Percent	N	Percent
CL	272	100.0%	0	0.0%	272	100.0%

**Descriptives**

		Statistic	Std. Error
CL	Mean	1.2030147	.06190338
	95% Confidence Interval for Mean		
	Lower Bound	1.0811420	
	Upper Bound	1.3248874	
	5% Trimmed Mean	1.0694771	
	Median	1.0712500	
	Variance	1.042	
	Std. Deviation	1.02093667	
	Minimum	.00000	
	Maximum	7.87500	
	Range	7.87500	
	Interquartile Range	.28844	
	Skewness	3.505	.148
	Kurtosis	17.690	.294

**CL**

The SCADA system contain the digital values of the real time readings, with Alarm toggle if its Higher than the recommended, and the data file tabulated these values every 0.5 sec. All these values saved in the memory of the computer and then we can use it's again as shown in the Fig.14, using data script of CICON software.

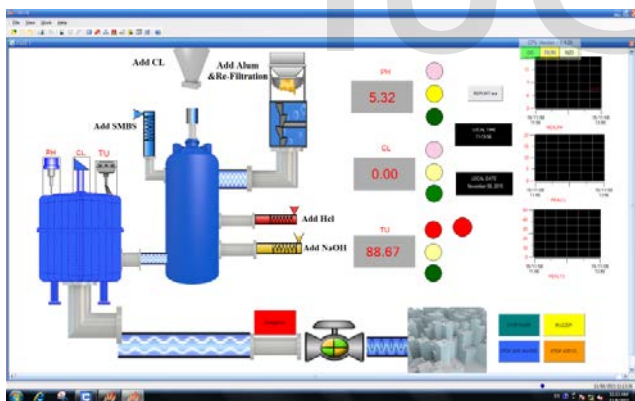

Fig.14 script of water SCADA system

This program is so reliable and it is so easy to change the setting points of high and minimum values of the sensors and the samples intervals. The real time data can be monitored and may be transmitted by any communication system which is out the scope of this paper.

**5 CONCLUSION**

The water quality control system is described, and the working process of SCADA module, of monitoring is

introduced. The software design of water quality collection is explained, the multi-state, multi-task, multithread reading software designing idea is advanced Tests show that the system has stable performance, good timeliness and low operation cost, which can meet the need of water quality monitoring under the new situation.

There are many benefits for using the SCADA system for monitoring the water properties:

- Centralize Water station monitoring and Control: SCADA permits monitoring and control of all activities of the water properties from a single location. Immediate detection of problems through diagnostic displays enables quick intervention for fast resolution.

- Increase Reliability & Improve Treatment Processes Automation: Effectively managing monitoring and distribution activities is vital to efficient Water Treatment Plant.

- Reduce Costs: The SCADA solution can significantly reduce operating and maintenance costs of water sampling and laboratory processes. A centralized SCADA system minimizes resource and maintenance expenditures by requiring fewer personnel to monitor the field and reducing daily maintenance trips.

**REFERENCES**

[1] Distribution System Water Quality Monitoring: Sensor Technology Evaluation Methodology and Results A Guide for Sensor Manufacturers and Water Utilities. EPA 600/R-09/076, 2009

[2] Michael Barnett and others, "Real-time Automation of Water Supply and Distribution for the City of Jacksonville" Florida, USA. Gensym Corporation, 2004.

[3] Jentgen, L.A. and D. Curtice, J. Jacobs, E. Kawczynski, K. Carns, "Advanced Control System for Water Utility Energy and Water Quality Management," Electric Power Research Institute, Community Environmental Center (CEC) Report CR-105742,1995.

[4] Jentgen, L.A. and D. Curtice, J. Jacobs, E. Kawczynski, K. Carns, ". Energy and Water Quality Management System," , 1997.

[5] Jentgen, L.A. and E. VonSacken, K. Stone, S.Ranade, W. Grayman, S. Conrad, "Implementing a Prototype Energy & Water Quality Management System," , 2003.

[6] Mr. Prashantpalkar and others, "Automation in drinking water supply distributed system and testing of water," IOSR Journal of Electronics & Communication Engineering (IOSR-JECE) ISSN: 2278-2834, ISBN: 2278-8735, PP : 36-38

[7] Michaud, J.P, "A citizen's guide to understanding and monitoring lakes and streams," Publ. #94-149. Washington State Dept. of Ecology, Publications Office, Olympia, WA, USA (360) 407-7472, 1991

[8] Moore, M.L, "NALMS management guide for lakes and reservoirs. North American Lake Management Society," Madison, WI, 53705-5443, USA , 1989

[9] Instruction manual of Model P7615, pH/mV Controller. Doc:pH/mV 7615/E - Rev:A

[10] Instruction manual of TU8355.

[11] InstructionManual of model CL 7365

[12] Iraqi criteria and standards for drinking water, IQS: 417:2009, ICS:  
13.060.20.

[13] Embedded Systems Engineering, <http://www.ledin.com/>

IJSER